



Innovation für die Lebensmitteltechnik

Eric, Lefebvre

26.04.2017



waschen



schneiden



schälen



trocknen



stanzen



verpacken



bohren



wiegen



entkeimen



reiben



mischen



entstielen

Meilensteine

Wichtige Innovationen und Veränderungen

Firmengründung
als Handelsunternehmen
für Hotel- und
Gastronomiegeräte

1978



Beginn der Entwicklung
und **Produktion** eigener
Maschinen für die Salat-,
Gemüse- und
Obstindustrie

1992



Übernahme von KRONEN
als mittelständischer
Betrieb durch den
geschäftsführenden
**Gesellschafter Rudolf
Hans Zillgith**

1998



waschen



schneiden



schälen



trocknen



stanzen



verpacken



bohren



wiegen



entkeimen



reiben



mischen



entstielen

Auf einen Blick

Unternehmenskennzahlen

Mitarbeiter

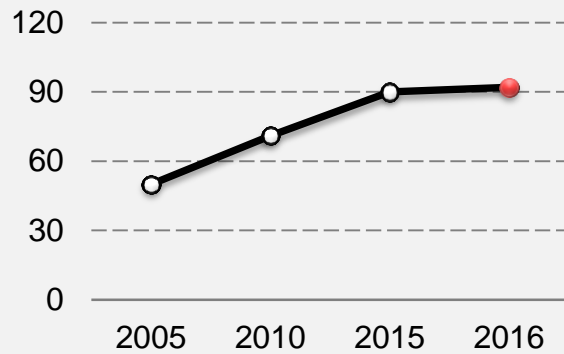

F & E Aufwendungen (in T. €)

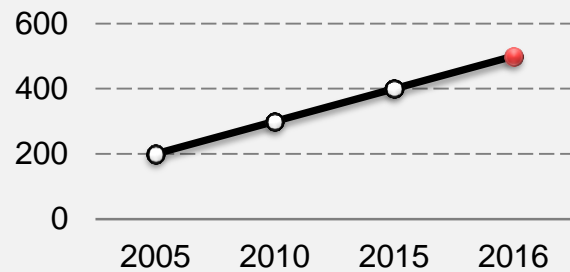

Umsatz (in Mio.€)

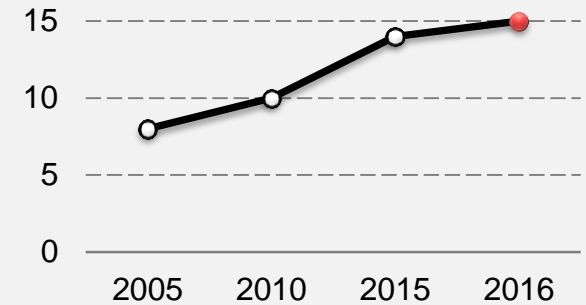

waschen



schneiden



schälen



trocknen



stanzen



verpacken



bohren



wiegen



entkeimen



reiben



mischen



entstielen

Von links nach rechts:

- **Robert Lankhart**
Manager Personal
IT / Logistik
- **Stephan Zillgith**
geschf. Gesellschafter
- **Johannes Günther**
Vertriebsdirektor
- **Rudolf Hans Zillgith**
geschf. Gesellschafter
- **Eric Lefebvre**
Technischer Leiter



waschen



schneiden



schälen



trocknen



stanzen



verpacken



bohren



wiegen



entkeimen



reiben



mischen



entstielen

Meilensteine

Wichtige Innovationen und Veränderungen

**Erste
Auslandsniederlassung**

KRONEN Corp. in
Cohoes, (NY).

2011



Einführung
der KRONEN **KAIZEN** Kultur
und **KRONEN Systems**

2012



KRONEN
SYSTEMS

Einführung **KRONEN**
Projektmanagement

2013



2015

Seit 2015 in Madison, (WI).



waschen



schneiden



schälen



trocknen



stanzen



verpacken



bohren



wiegen



entkeimen



reiben



mischen



entstielen

KRONEN ist in über 80 Länder für Sie vor Ort



waschen



schneiden



schälen



trocknen



stanzen



verpacken



bohren



wiegen



entkeimen



reiben



mischen



entstielen

Vielseitige Technologien in dem Produktsortiment

interessante Lösungen für die Verarbeitung von



Salat



Gemüse



Obst



Geflügel



Fleisch



waschen



schneiden



schälen



trocknen



stanzen



verpacken



bohren



wiegen



entkeimen



reiben



mischen



entstielen

Branchenübergreifende innovative Technologien in den Industrien

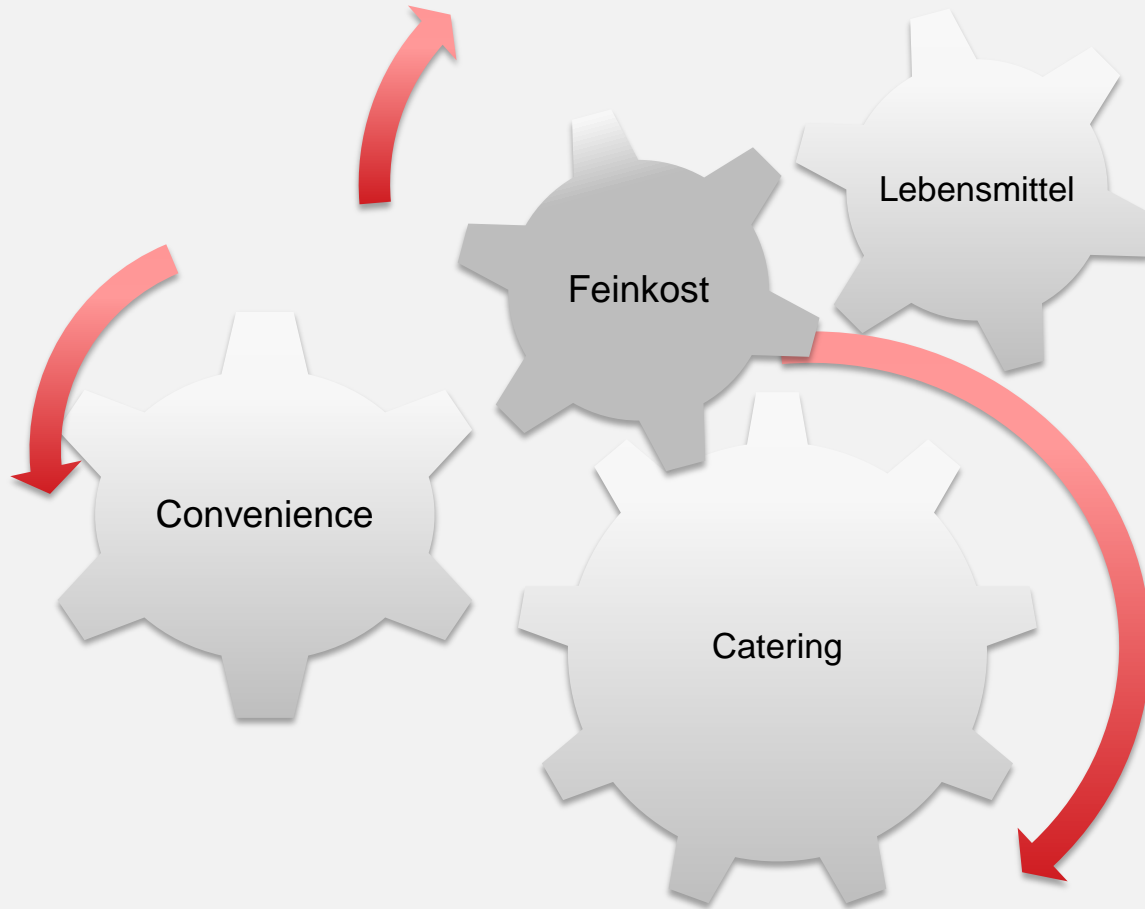

waschen



schneiden



schälen



trocknen



stanzen



verpacken



bohren



wiegen



entkeimen



reiben



mischen



entstielen

Branchenübergreifende innovative Technologien für jede Anwendung

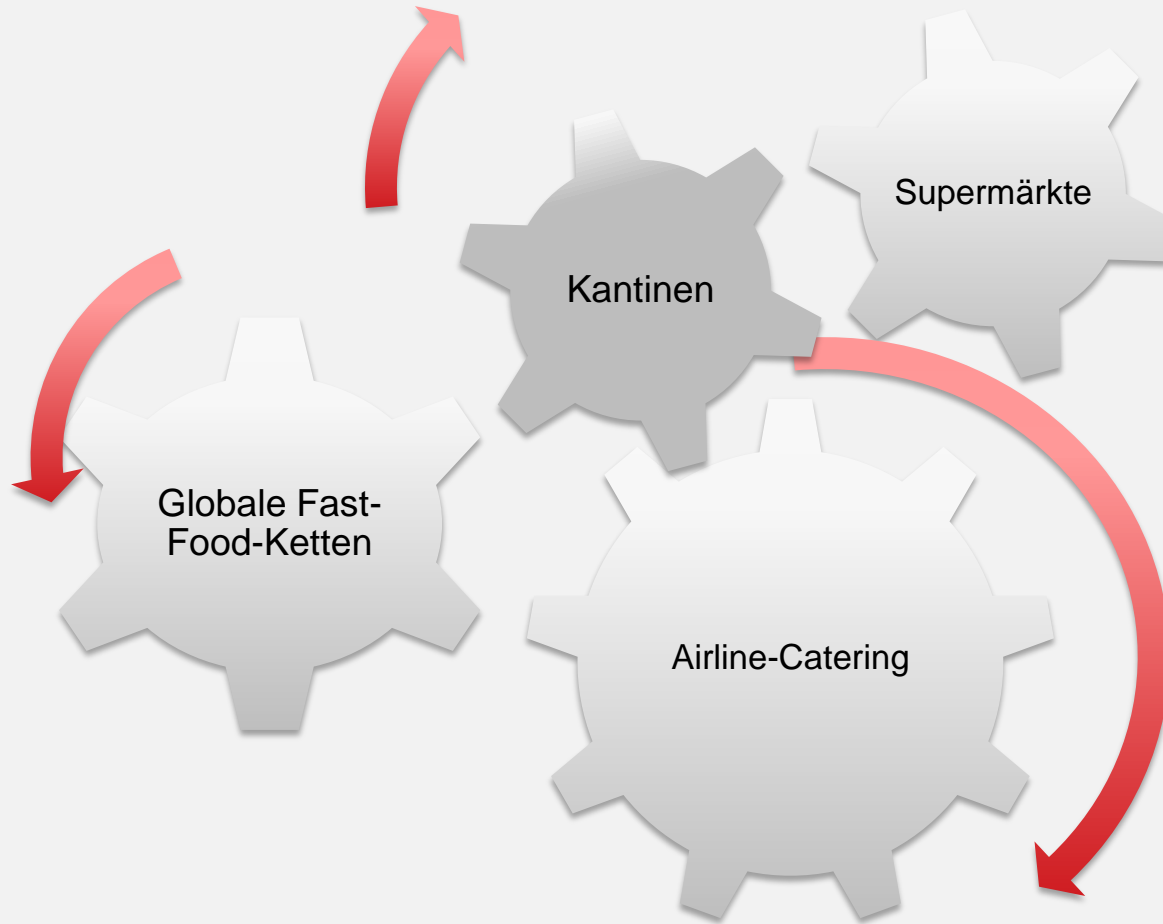

waschen



schneiden



schälen



trocknen



stanzen



verpacken



bohren



wiegen



entkeimen



reiben



mischen



entstielen

KRONEN Systems

Mit KRONEN Zukunft gestalten



waschen



schneiden



schälen



trocknen



stanzen



verpacken



bohren



wiegen



entkeimen



reiben



mischen



entstielen

KRONEN Systems

Die Fertigung der Zukunft mitgestalten

Mit Kronen-Systems gestalten wir die Maschinen von Anfang an mit und setzen entscheidende Impulse auf dem Weg in die Zukunft.

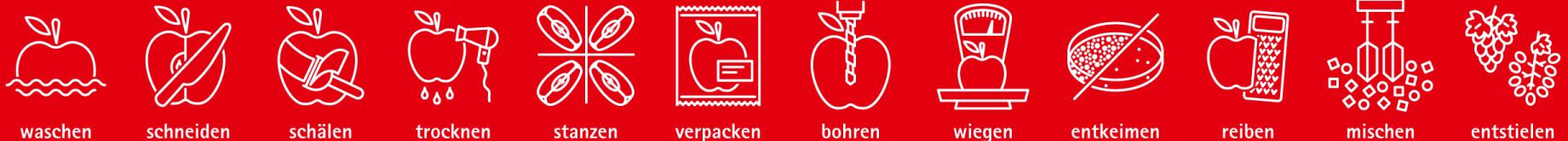

Energie



Nachhaltigkeit

Wasser



**Innovation in der
Waschtechnik**

**Nahrungsmittelsicher
heit**



Hygiene

Reinigbarkeit

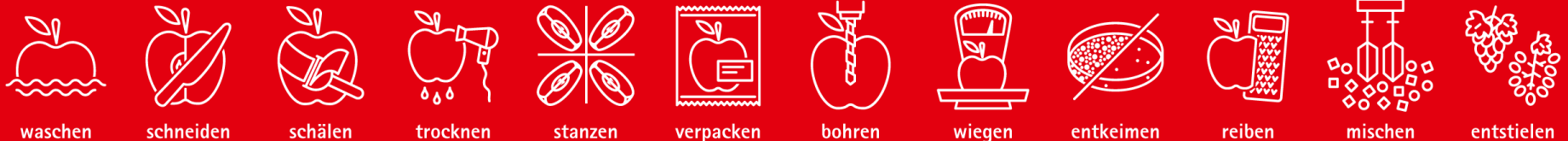

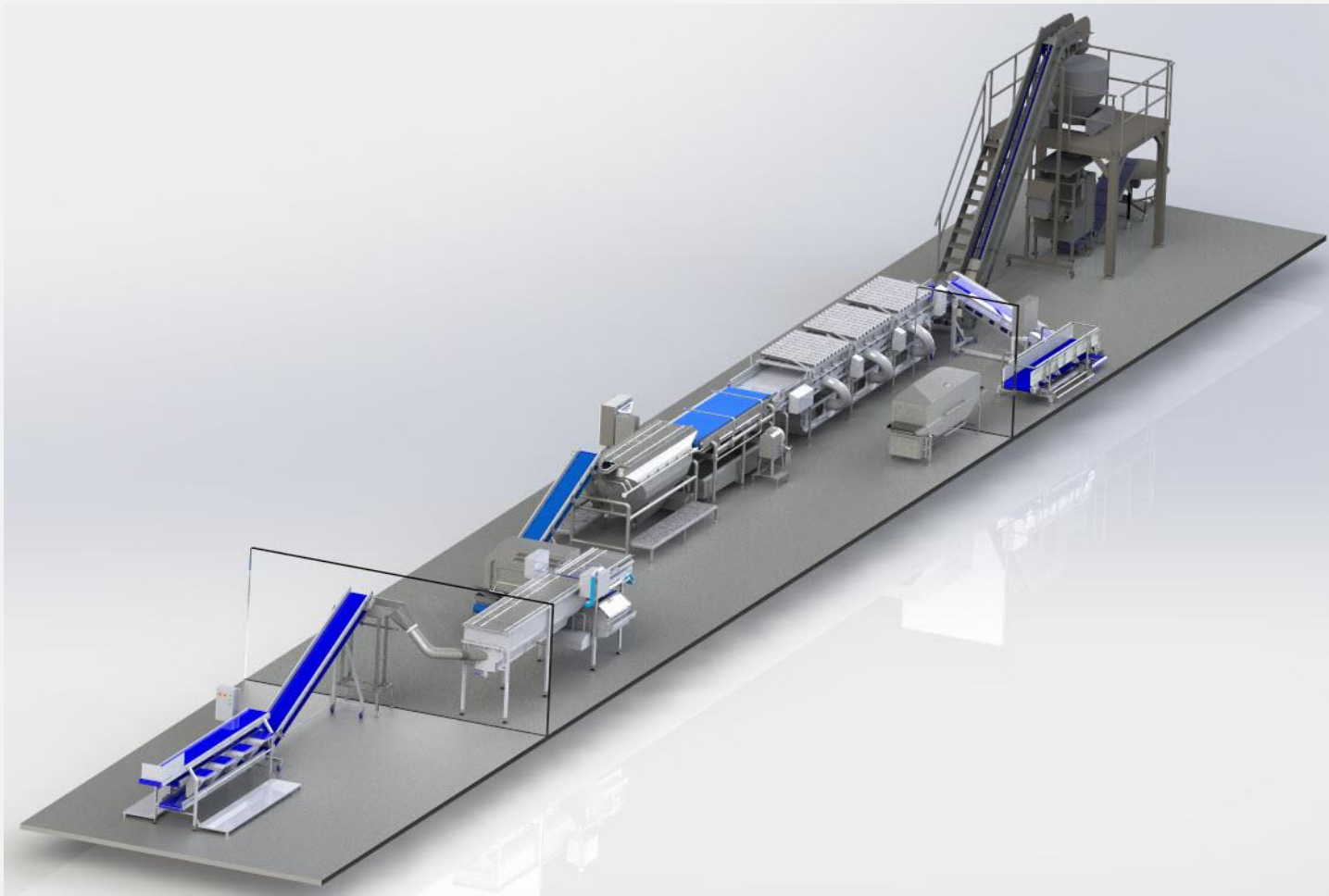

waschen



schneiden



schälen



trocknen



stanzen



verpacken



bohren



wiegen



entkeimen



reiben



mischen



entstielen

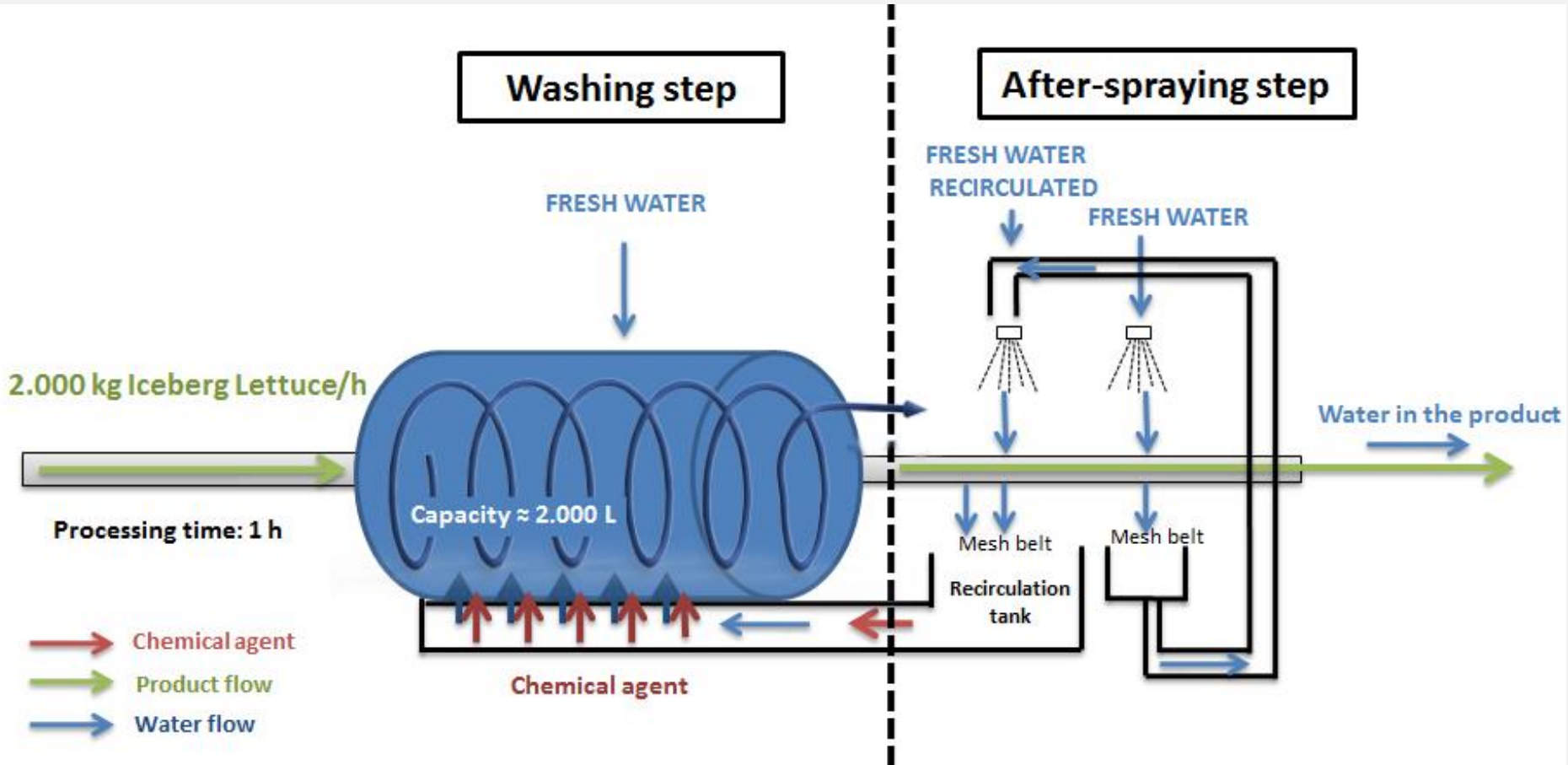

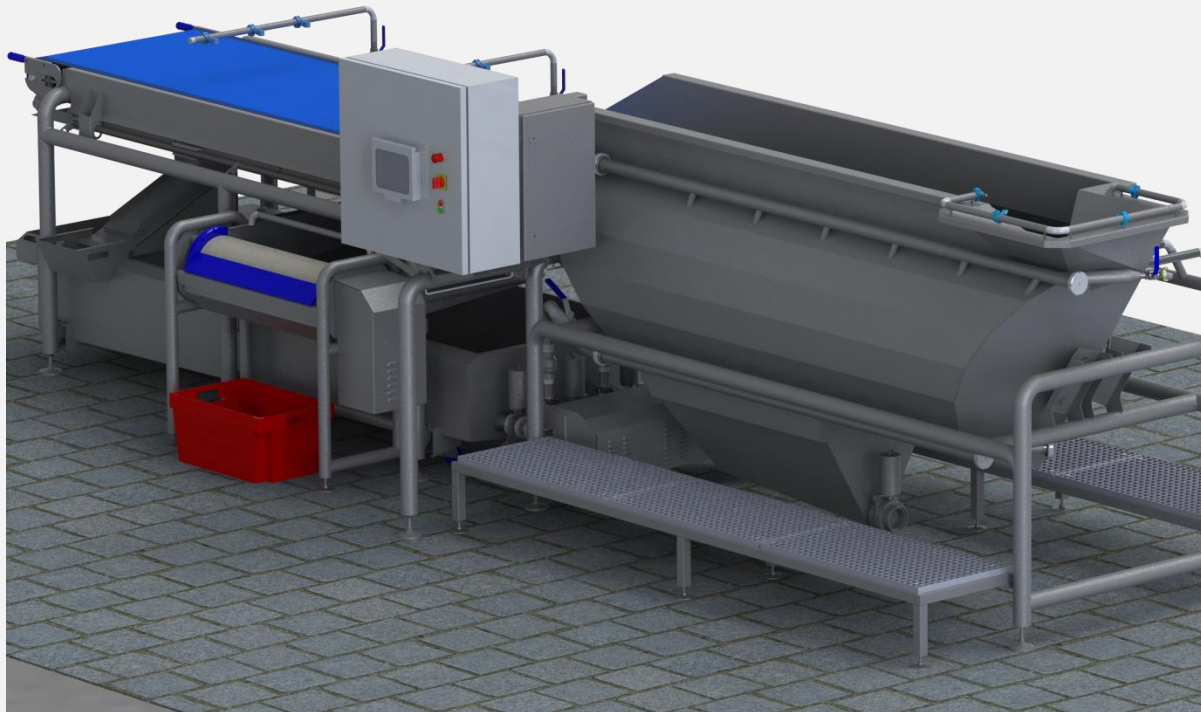

Waschtank: 1950 Liters
Filtertank: 1050 Liters

Energie
Waschbereich: 9 kW
Trockenbereich: 4,4 kW

Kapazität
Babyleaf: 1500 kg/h
Eisberg: 5000 kg/h



waschen



schneiden



schälen



trocknen



stanzen



verpacken



bohren



wiegen



entkeimen



reiben



mischen



entstielen

Simulation: keine Düsen mehr, gute Wasser Verteilung, weniger Energie

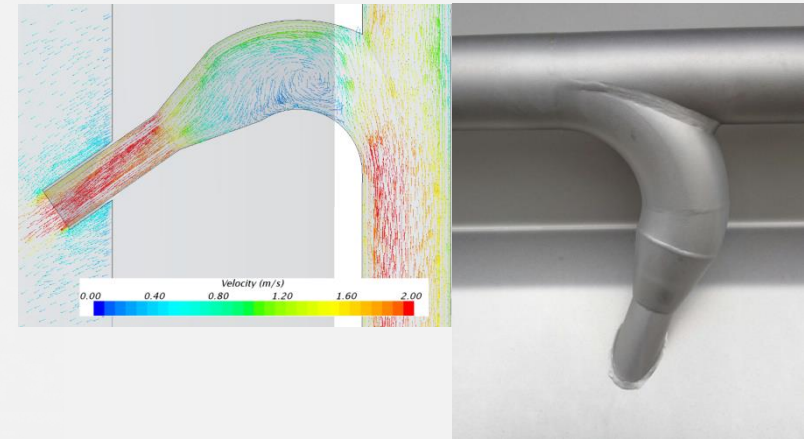
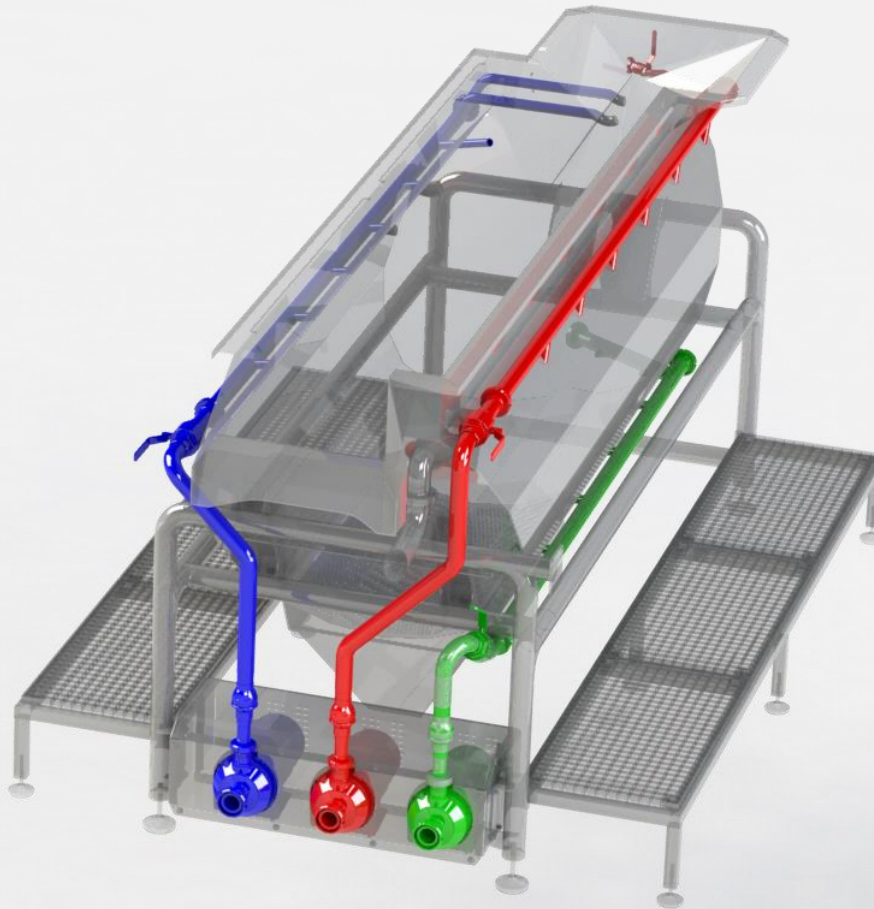

waschen



schneiden



schälen



trocknen



stanzen



verpacken



bohren



wiegen



entkeimen



reiben



mischen



entstielen

Simulation: 45 Sekunden Verweilzeit, offene Winkel, keine Luft

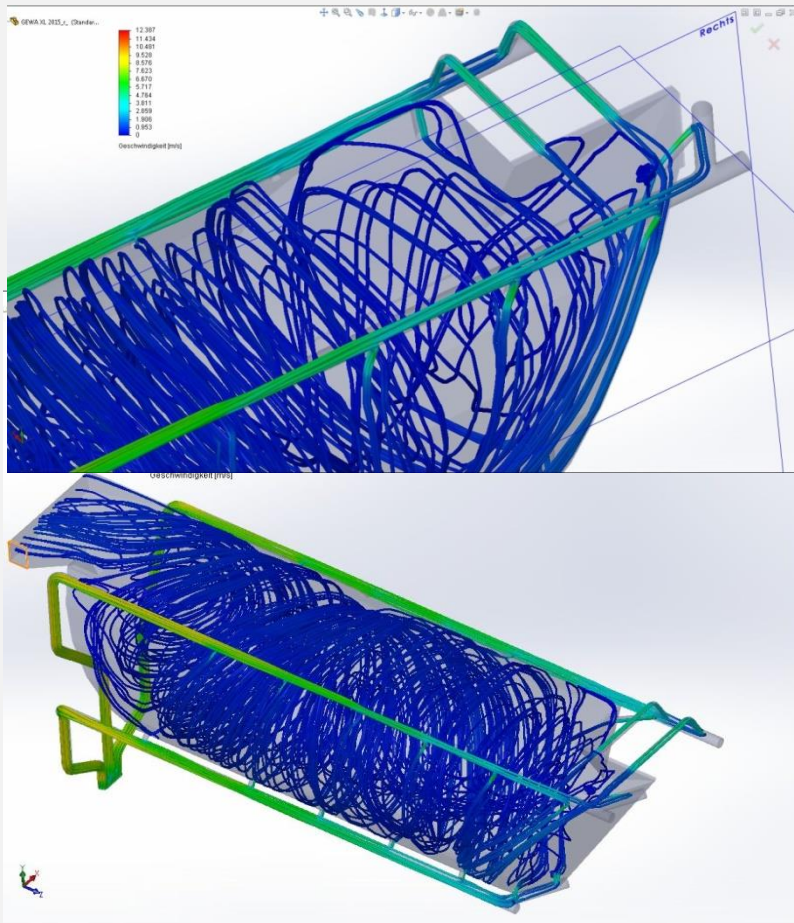

Doppel Dusche, keine Seitenführung, entspannbares Band, offenes System, Luft Ansaugung





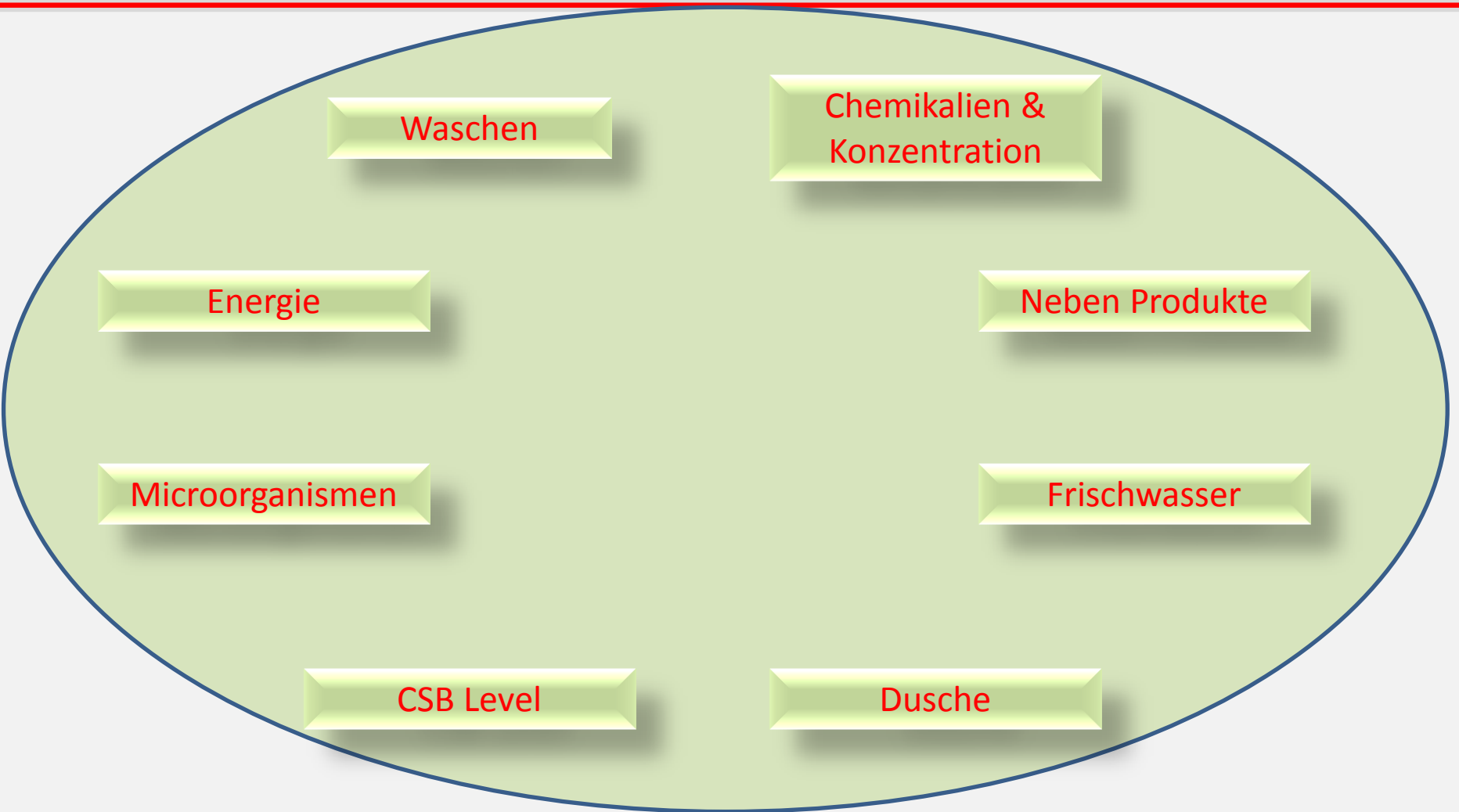

Produktionsfläche Waschtank:

- Floating: 6 m²
=> 30 cm²/kg/h
- Helical: 2 m²
=> 20 cm²/kg/h
- GEWA XL: 4,2 m²
=> 21 cm²/kg/h
=> Achieved 9 cm²/kg/h

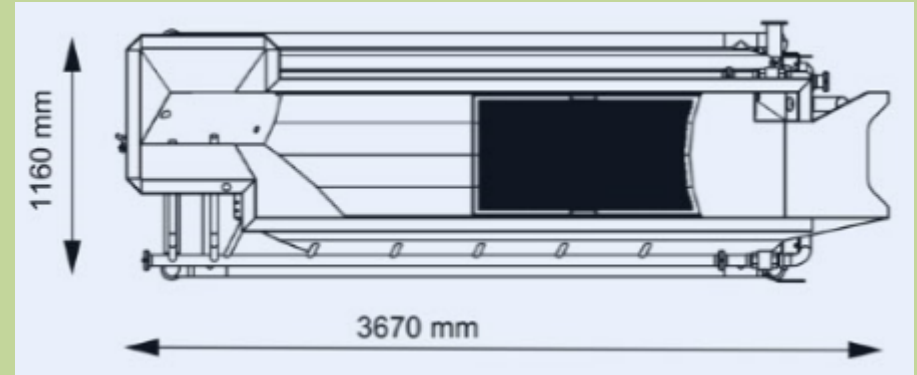

Biofilm

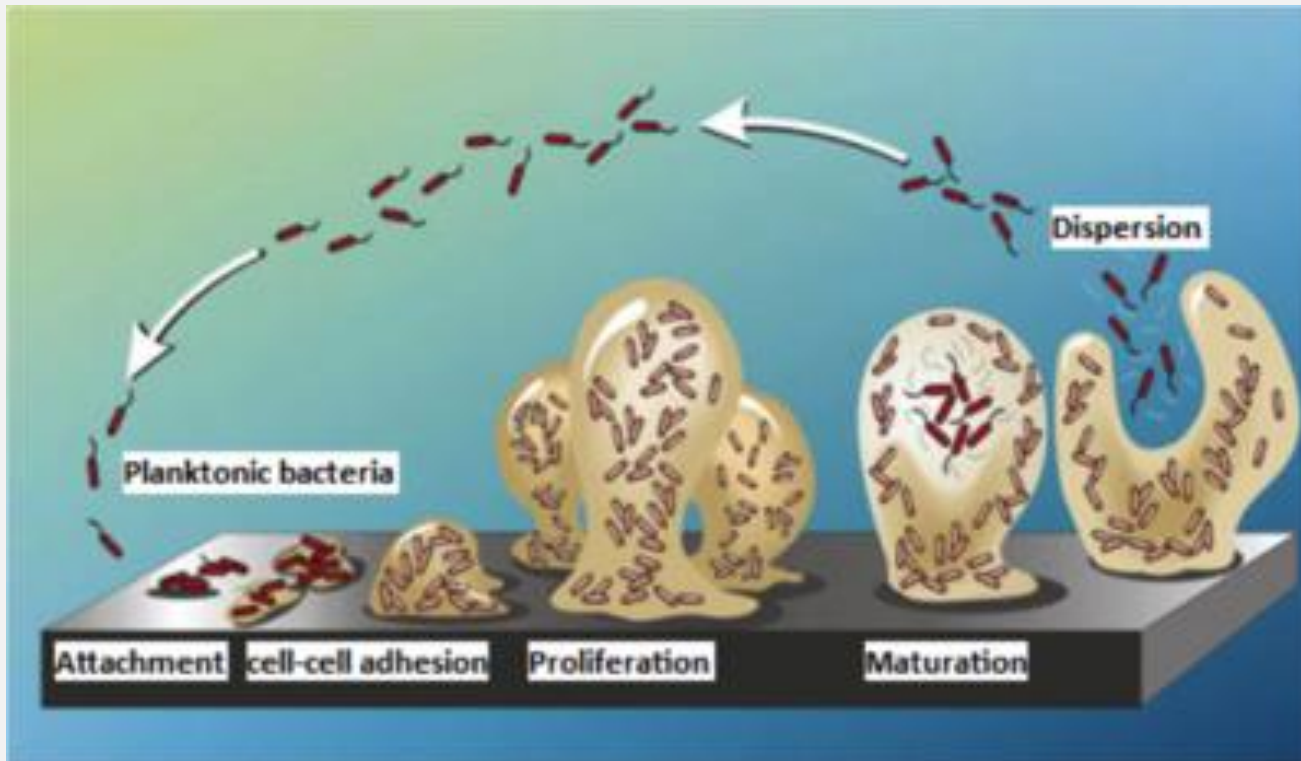

waschen



schneiden



schälen



trocknen



stanzen



verpacken



bohren



wiegen



entkeimen



reiben



mischen



entstielen

KRONEN Destain / KRONEN Destain Plus

Universalreiniger

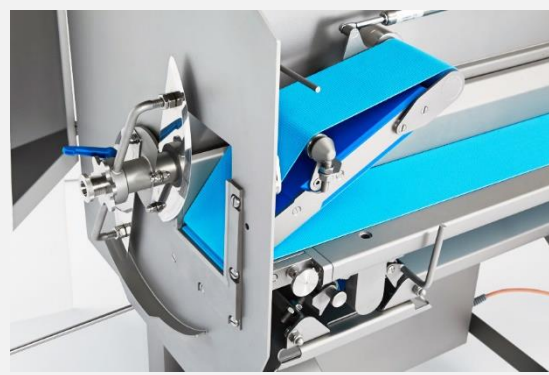

- 
waschen
- 
schneiden
- 
schälen
- 
trocknen
- 
stanzen
- 
verpacken
- 
bohren
- 
wiegen
- 
entkeimen
- 
reiben
- 
mischen
- 
entstielen

Innovation für die Lebensmitteltechnik

Eine Erfolgsgeschichte wird fortgeschrieben



Eric Lefebvre

Technischer Leiter

KRONEN GmbH

Römerstraße 2a

D-77694 Kehl am Rhein

Tel.: +49 (0)7854 9646-431

Mobil: +49 (0)173 6791368

Fax: +49(0)7854 9646-5431

E-Mail: eric.lefebvre@kronen.eu

www.kronen.eu



**VIELEN DANK FÜR IHRE
AUFMERKSAMKEIT !!!**



waschen



schneiden



schälen



trocknen



stanzen



verpacken



bohren



wiegen



entkeimen



reiben



mischen



entstielen